

# Information is Power

By measuring intensity (heart rate) and duration (time) you can avoid over training, help prevent injury, and maximize your chances of achieving your goals.



## triax c8 features

- 50 lap chronograph
- Adjustable target heart rate zone
- 2 segment interval trainer
- Data: timing information, average heart rate, time in zone for each lap/run
- Time / Day / Date / Alarm

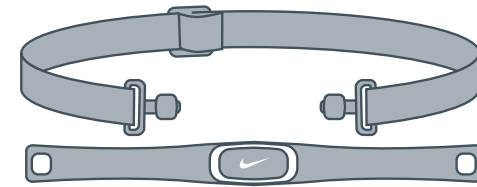
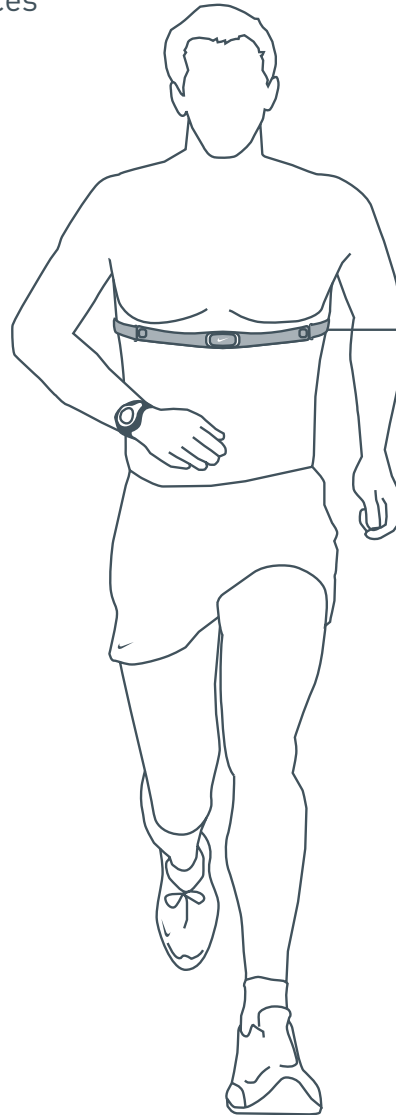

## Heart Rate Transmitter

Your Heart Rate Transmitter reads the electrical impulses of your heart and transmits data to your watch. It is one of the most accurate ways to measure heart rate. The Transmitter will function automatically if it is worn correctly within a meter of the watch. The Transmitter is ergonomically designed to fit comfortably during all types of exercise.

**ATTENTION:** Anyone beginning an exercise regimen for the first time (especially users of pacemakers or other implanted devices) should consult their physician or health professional before using the heart rate monitor.

# Contents

Quick Start .....	3
<b>TIME mode</b>	
Set Time .....	5
Set Alarm .....	6
<b>RUN mode</b>	
Using the Chronograph .....	7
Setting Heart Rate Zone .....	9
Customizing Primary Display .....	10
Setting “My View” Display .....	11
<b>INTERVAL mode</b>	
Setting Training Intervals .....	12
<b>DATA mode</b>	
Review Saved Runs .....	13
Heart Rate Intensity Chart .....	14
Troubleshooting .....	15
Specifications .....	15
Battery .....	16
Warranty .....	17
Service Centers .....	17
CE Compliance .....	17

This document with updates is available online at [www.niketiming.com](http://www.niketiming.com)

Printed on Wood Free Paper

## Quick Start

Follow steps 1 through 7 to position the Heart Rate Transmitter and go for a run.



1 Push tab up through slot in HR Transmitter.

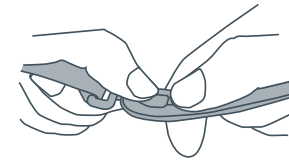

2 Press down tab until flush.

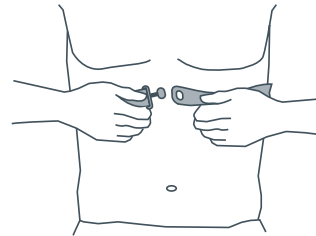

3 Attach other side of HR Transmitter around chest. Position on rib cage just below the breast plate. Should be worn directly against skin and snug enough to not slip down while running.

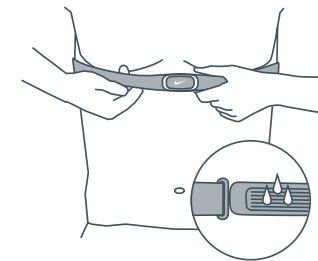

4 Generously **wet both grooved areas** on the back of HR Transmitter to ensure a good pick up between your pulse and the Transmitter.

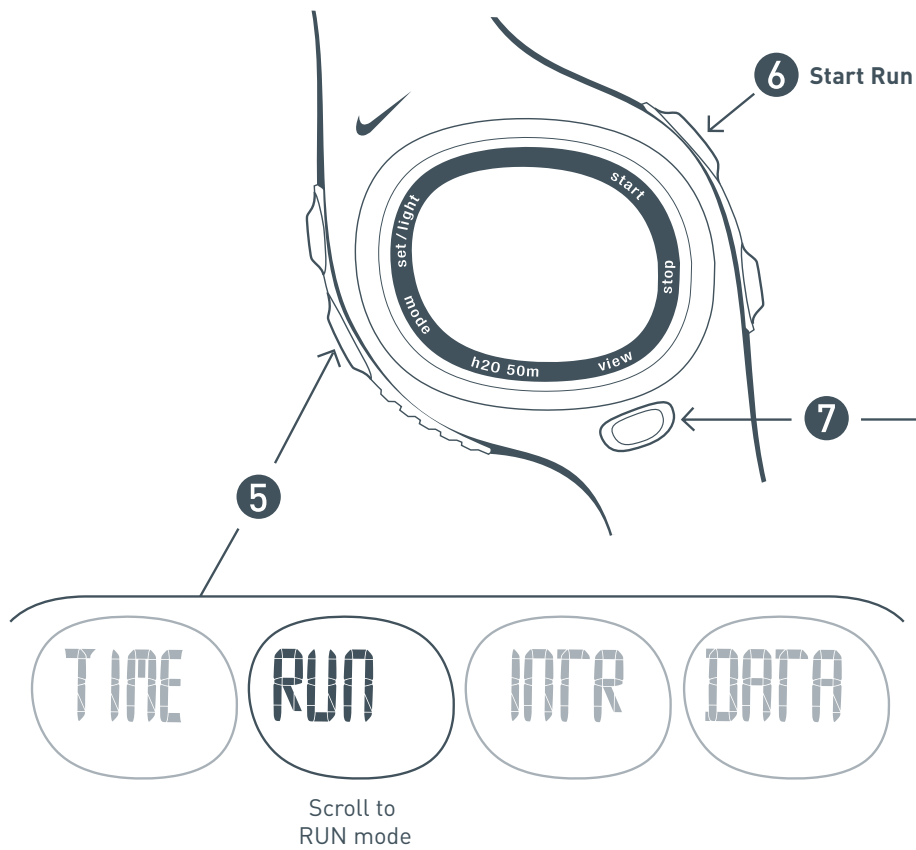

RUN mode views



Chronograph View

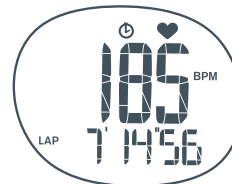

Heart Rate View



My View  
See page 11 for setup

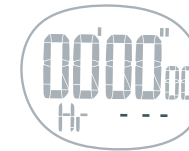

or



**No Heart Rate Displayed**

If you see three blinking lines in the display, the watch is not receiving transmission from the Heart Rate Transmitter.

Run through the *Quick Start* again or see page 15 *Troubleshooting*.

# TIME Set Time

In TIME mode you can set the time, date and power save option. TIME mode is the only mode in which you can turn the button chime ON and OFF. Follow steps 1 through 5 to set the time and date.

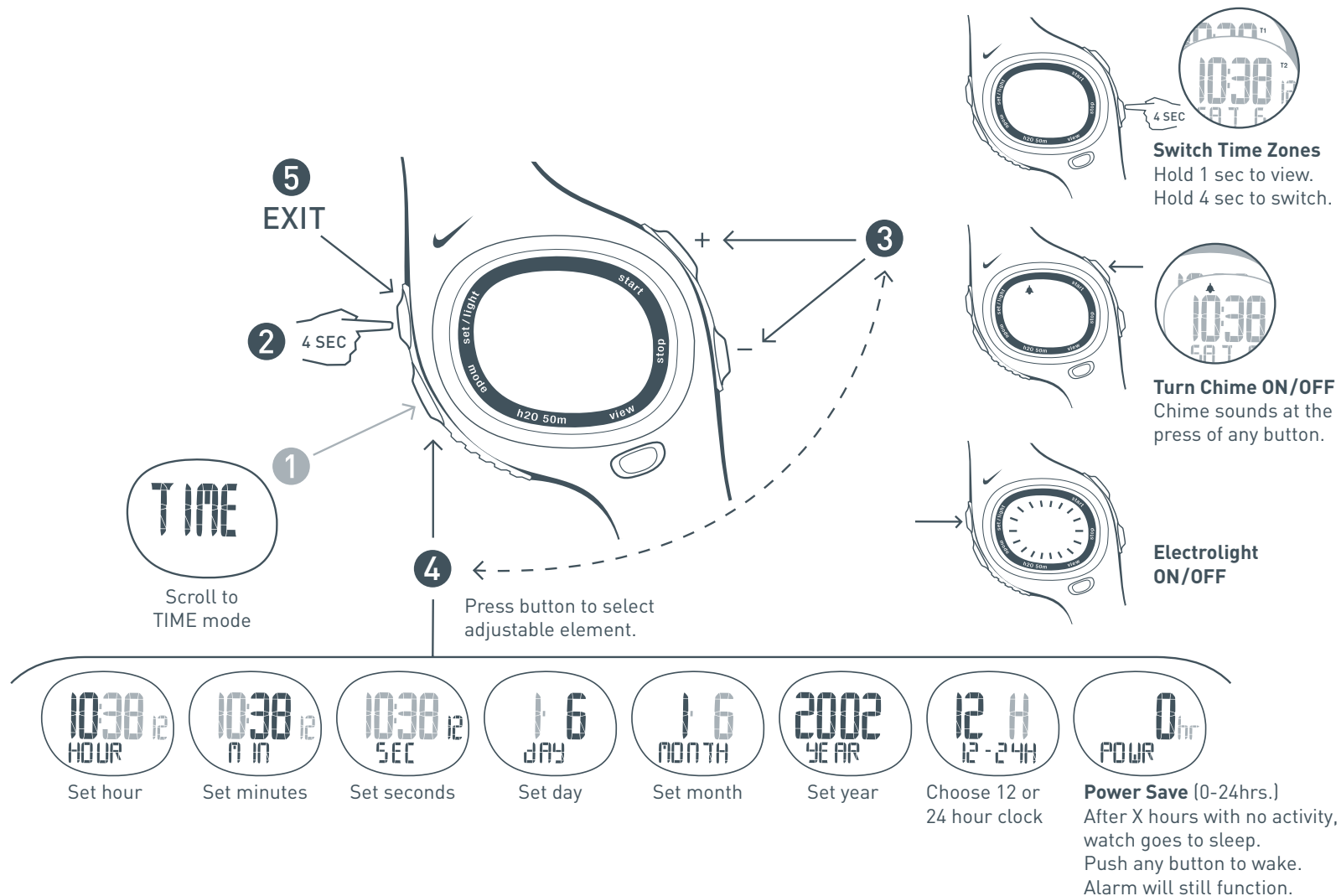

# TIME Set Alarm

Within TIME mode you can set two alarms. Follow steps ❶ through ❹ to set the alarms.

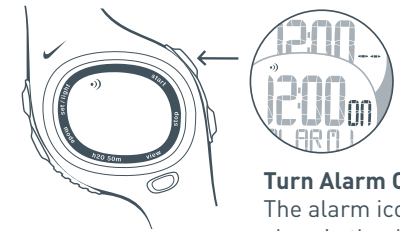
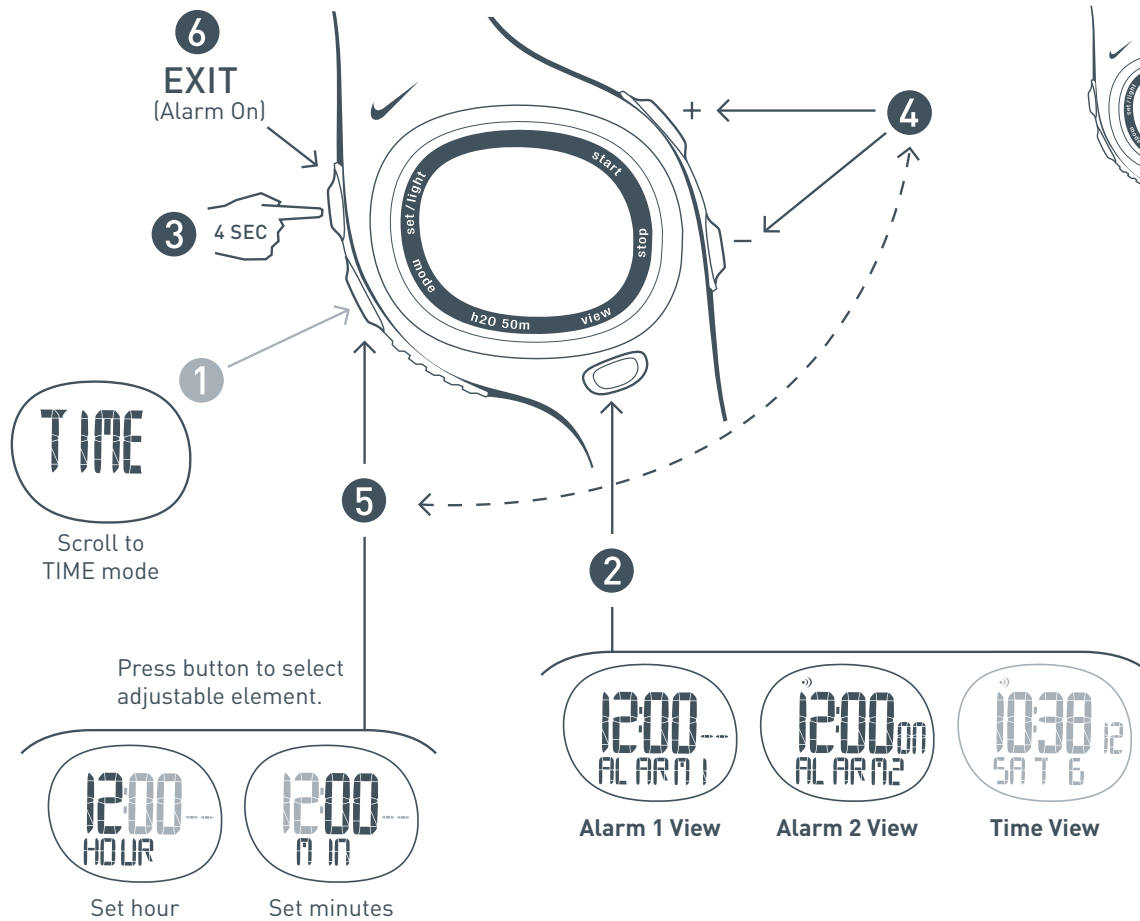

**Turn Alarm ON/OFF**  
The alarm icon  will show in the display of any mode when the alarm is turned ON.

# RUN Using the Chronograph

In Chronograph View, you can mark lap times and total times during your run. Both lap times and total times are captured simultaneously when you press the lap button. Average heart rate is also captured for each lap/total period. After you stop the chronograph, you can save your run information and review it in DATA mode. See page 13 for DATA mode. Follow steps 1 through 6 to use your chronograph.

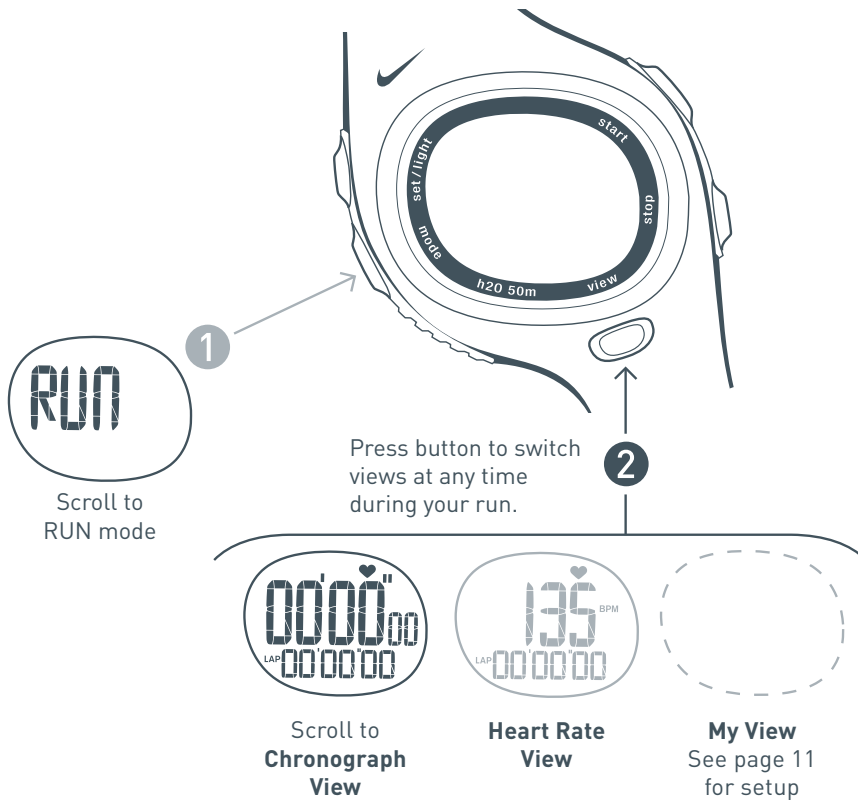

## Mark Laps

Lap time is the time required to go once around a track or complete a segment of a run.



## LAP 1



and

## Mark Totals

Total time is the time from the beginning of the run up to the point you mark.



## TOTAL 1

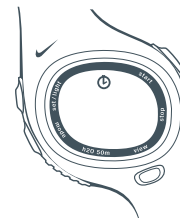

3

**Start Run**  
A blinking stopwatch ⌚ will appear.

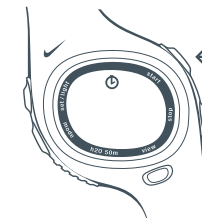

4

**Mark Lap/Total**  
You will have 7 seconds to read your lap and total time.

Heart rate is also captured for each lap/total period and can be viewed in DATA mode if the run is saved.

## 6 ... Save or Clear Run Information

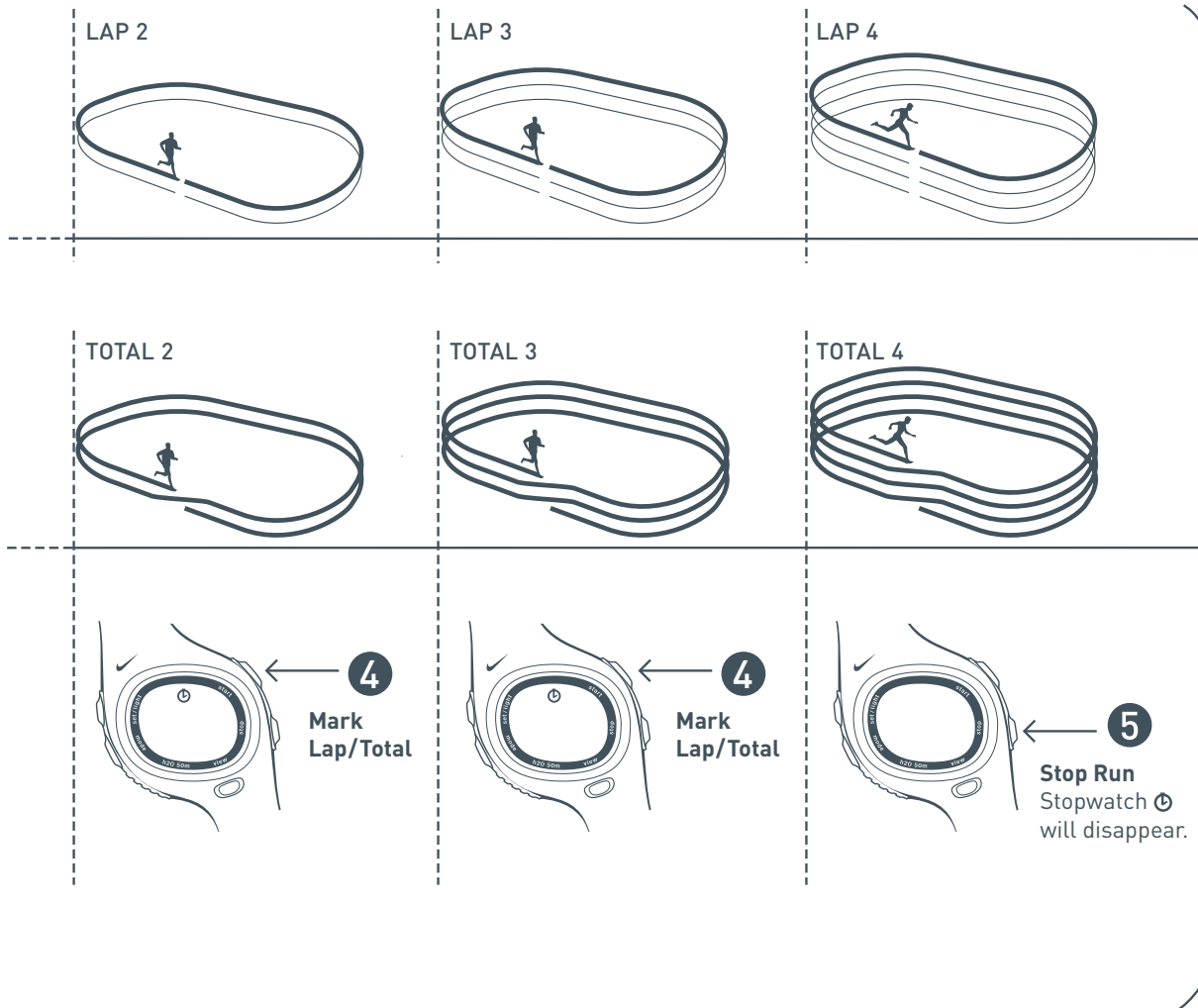

**Save Run**  
Run information is saved to DATA mode.

See page 13 for DATA mode.

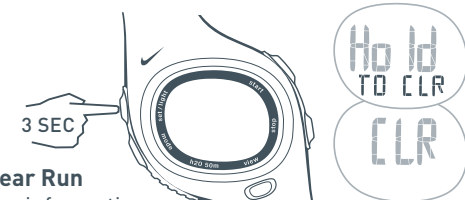

**Clear Run**  
Run information is erased.

# RUN Setting Heart Rate Zone

Your heart rate is measured in beats per minute (bpm). Setting a heart rate zone allows you to work within an upper and lower heart rate limit. Follow steps 1 through 5 to set a target heart rate zone.

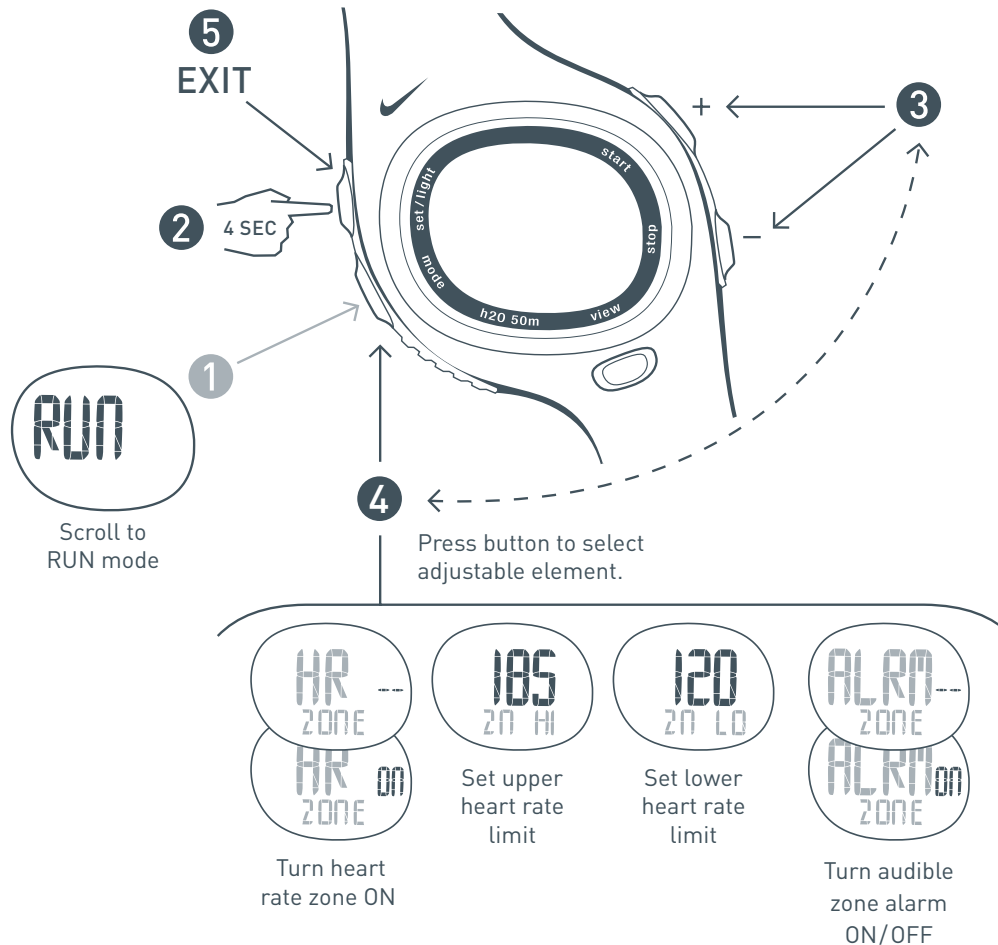

Above your heart rate zone.

or



Below your heart rate zone.

### Out-of-Zone Indicators

If your heart rate is out of your zone the LO (▼) or HI (▲) arrow indicators will flash in the display.



### Zone Alarm ON Indicator

If zone alarm is ON the watch will beep as your heart rate moves out of your zone.

# RUN Customizing Primary Display

You can choose to view TOTAL time or LAP time in the primary display of your chronograph. Follow steps 1 through 5 to switch your views.

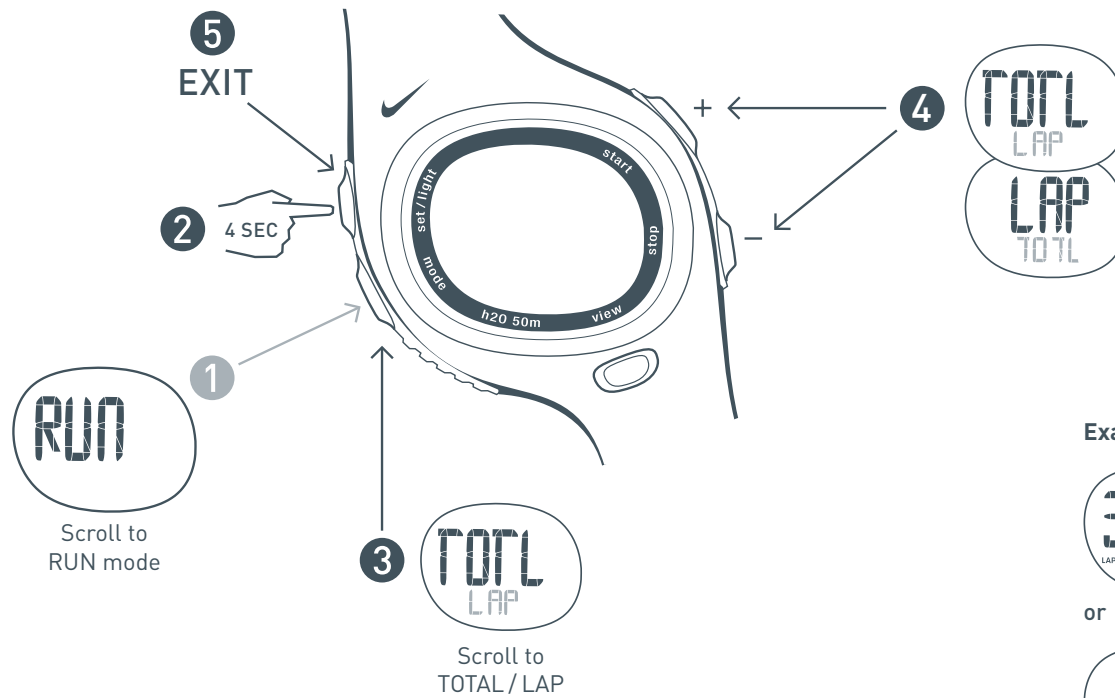

## Examples



TOTAL time  
in primary display.

or



LAP time  
in primary display.

# RUN

## Setting “My View” Display

“My View” allows you to create your own view in RUN mode with the information you use the most during your workout. When activated My View will appear as the first view in RUN mode. This feature allows you to choose which information appears in the Primary (larger) and the Secondary (smaller) displays. Follow steps ① through ⑤ to create your view.

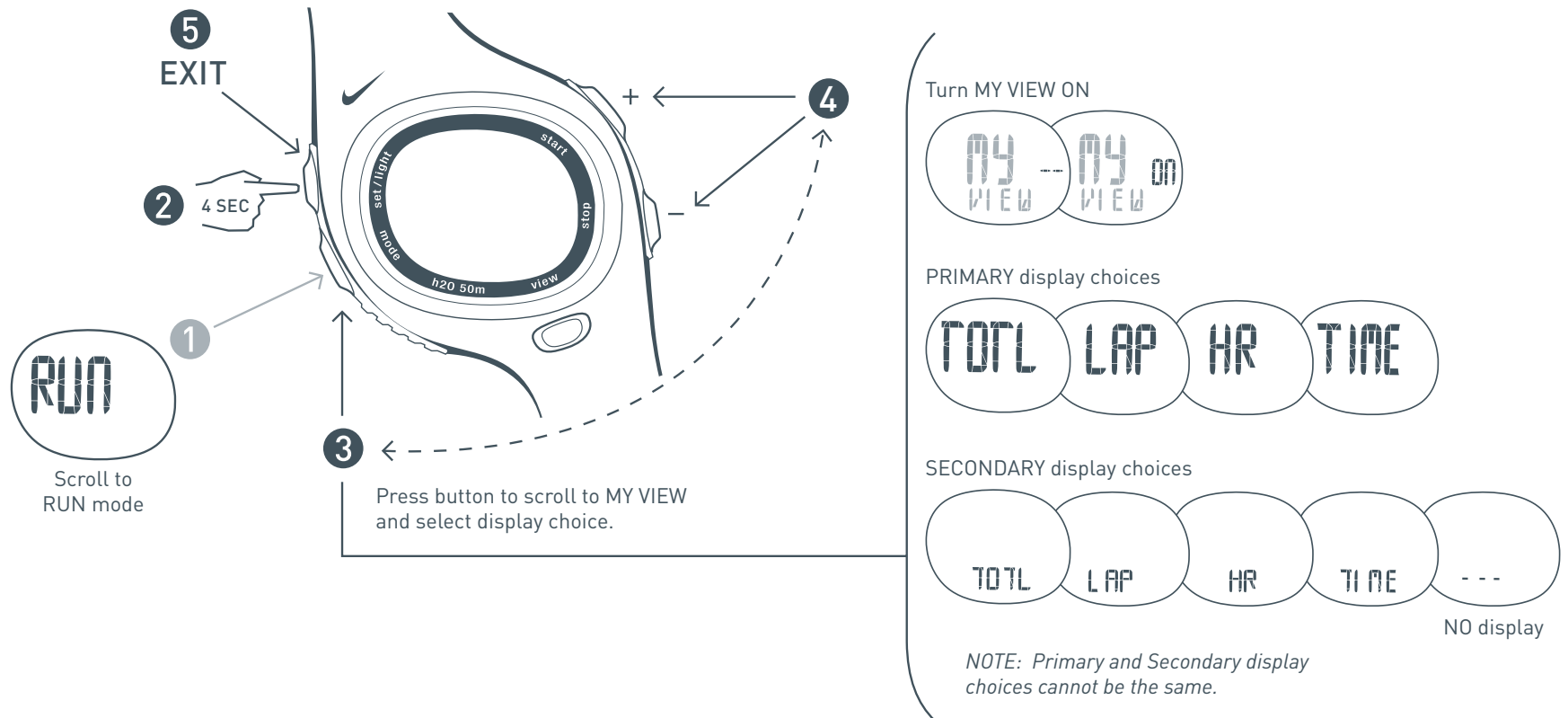

# INTR Setting Training Intervals

INTERVAL mode features a 2 segment countdown timer. You can use this as an interval training tool by exercising at a higher intensity for a certain period of time, followed by a recovery interval at a lower intensity level. You can set 2 timed segments for your workout. As each segment is completed, the next begins. All segments will continue to repeat until the timer is stopped. Follow steps 1 through 5 to set your training intervals.

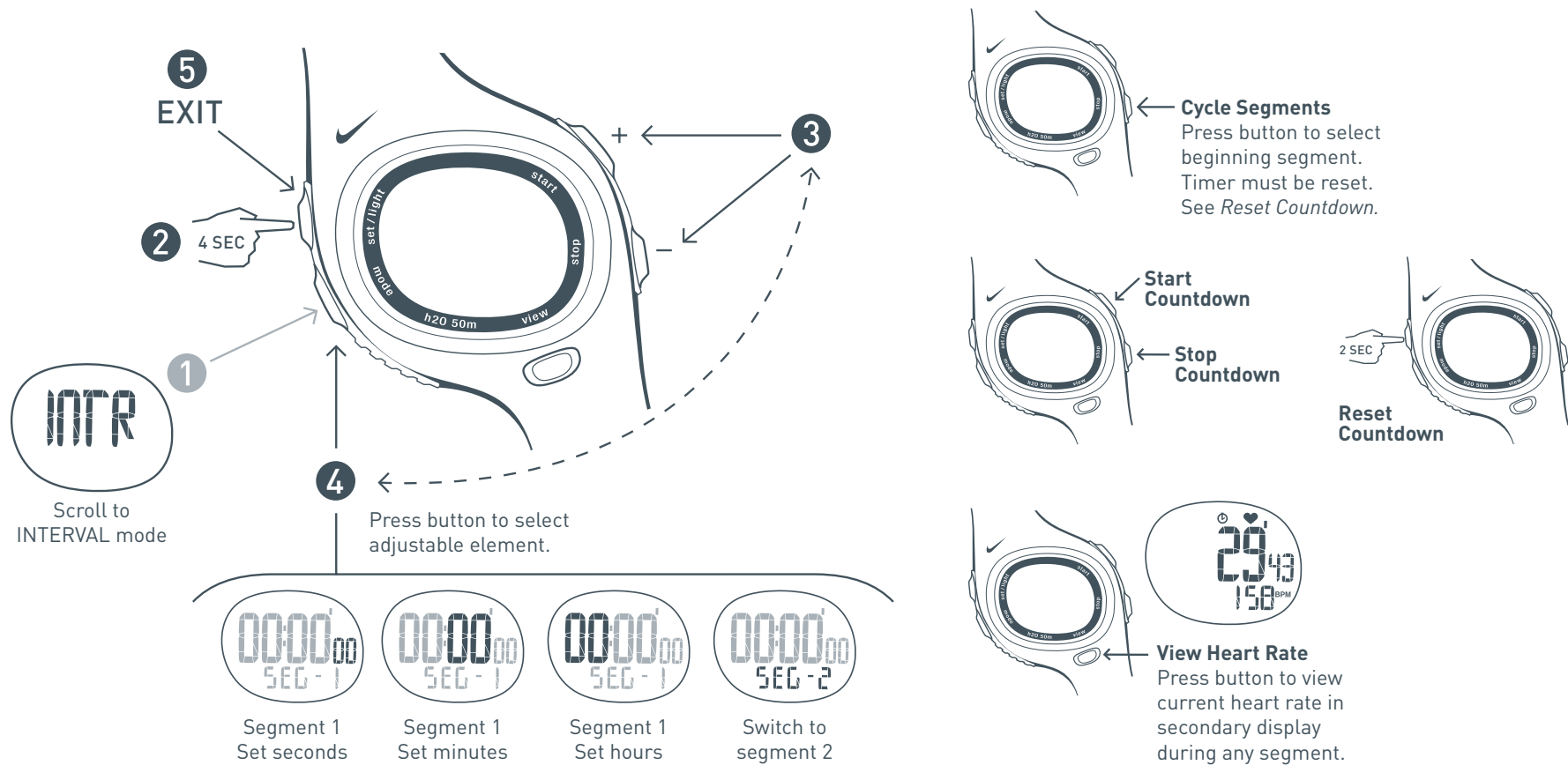

# DATA Review Saved Runs

In DATA mode you can review detailed information about your saved runs. The memory can store multiple runs with up to 50 laps each. See page 8 for saving runs to DATA mode. Follow steps 1 through 4 to view data saved for each run.

**1** Scroll to DATA mode

**2** Select a Run  
Date of run appears in primary display.

**3** Press button to view stats in each category.

**4** Press button to view stats in each category.

Total Time	Averages	HR Zone	Best Lap	Lap 1	Lap 2	Lap 3 up to 50
3354 <sup>16</sup> TOTAL	744 <sup>06</sup> AVG	303 <sup>125</sup> HR: 17	714 <sup>43</sup> BEST	714 <sup>43</sup> LAP 1	739 <sup>20</sup> LAP 2	
	Average HR 162 AVG	Above Zone 212 <sup>85</sup> HR: 16		Total Time 714 <sup>43</sup> LAP 1	Total Time (Lap 1 + Lap 2) 1453 <sup>63</sup> LAP 2	
	Average Lap 744 <sup>06</sup> AVG	Below Zone 111 <sup>06</sup> HR: 6		Average HR 159 LAP 1	Average HR 165 LAP 2	
		In Zone 303 <sup>125</sup> HR: 17		Lap 1 Time 714 <sup>43</sup> LAP 1	Lap 2 Time 739 <sup>20</sup> LAP 2	

HR Zones will not appear if they are turned OFF during recording.

**Clear This Run**  
NOTE: If RUN 2 is deleted, RUN 3 becomes RUN 2.

**Clear ALL Runs**

# Heart Rate Intensity Chart

This is another way to gauge your approximate heart rate zones based on sex, age and weight. Starting with your Max Heart Rate, use the chart to help calculate your zones depending on the intensity of your workout. Note this formula may not work for everyone.

Find your Max Heart Rate	Determine your Target Heart Rate Zones (Intensities)			
$210 - (.7 \times \text{age})$	<p><b>Light Intensity (60-70% of Max HR)</b> Exercise in this range at the start of a workout or to recover from a tough workout or race. You should be able to easily maintain a conversation while exercising at this intensity.</p>	<p><b>Moderate Intensity (70-80% of Max HR)</b> Exercise in this range to develop endurance and prepare your muscles to make the transition from aerobic to anaerobic. You should be able to maintain this for a while. You should not be completely breathless and this should not hurt.</p>	<p><b>Heavy Intensity (80-90% of Max HR)</b> Exercise in this range to increase muscle strength and improve your anaerobic threshold. This is uncomfortable. You should be breathing very heavily. You should only be able to sustain this for a brief time.</p>	<p><b>Maximum Intensity (90-100% of Max HR)</b> Exercise in this range to increase mental toughness, Max V02 and tolerance to lactic acid. This is very uncomfortable. You can barely sustain it. You should be completely breathless. Do not exercise at this intensity except on the advice of a trained medical professional.</p>

## Max Heart Rate

205 bpm	123 - 143 bpm	144 - 163 bpm	164 - 184 bpm	184 - 205 bpm
200	120 - 139	140 - 159	160 - 179	180 - 200
195	117 - 136	137 - 155	156 - 175	176 - 195
190	114 - 132	133 - 151	152 - 170	171 - 190
185	111 - 129	130 - 147	148 - 166	167 - 185
180	108 - 125	126 - 143	144 - 161	162 - 180
175	105 - 122	123 - 139	140 - 157	158 - 175
170	102 - 118	119 - 135	136 - 152	153 - 170
165	99 - 115	116 - 131	132 - 148	149 - 165
160	96 - 111	112 - 127	128 - 143	144 - 160
155	93 - 108	109 - 123	124 - 139	125 - 155
150	90 - 104	105 - 119	120 - 134	121 - 150

## Troubleshooting

### No heart rate displayed on watch:

The grooved sensors may not be wet enough. Wet and try again. It is recommended that you wear the Heart Rate Transmitter directly against your skin. If you are wearing the HR Transmitter over clothing, try getting the clothing wet also.

The HR Transmitter may not be positioned correctly. Make sure the grooved sensors are flat against the skin.

### Heart rate reading on watch is erratic or stops:

You may need to replace the battery in the HR Transmitter.

Sources of electromagnetic fields like appliances, computers and power lines can cause interference. Change your location.

*This product complies with EN60601-1-2*

### Watch display is frozen:

The display of your watch may "freeze" due to static electricity or recent battery replacement. If this occurs, press and hold all four buttons at the same time. This will erase the data in the memory and allow you to reset the watch to the factory settings.

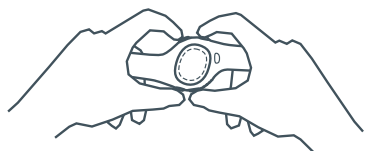

*Press and hold all four buttons at the same time to reset the watch to the factory settings.*

### Watch beeps continuously:

If you have the zone alarm on and your heart rate does not fall within any of your zones, the watch will beep to indicate you are out of your zones. See page 9 for instructions on how to turn off the zone alarm.

## Specifications

IP code: IPX8

Applied Part: Type CF

Storage: Standard Conditions (within operating temperature)

### Watch

#### Water Resistant up to 50 Meters:

Designed for underwater performance to a depth of 165 feet (50 m).

**ATTENTION:** Water damage will occur if watch buttons are pressed while underwater!

**Operating Temperature:** -5 to 50° Celsius

#### Material Specifications:

**Crystal:** Mineral Glass

**Case:** Polycarbonate

**Buckle:** Stainless Steel

**Bezel:** Stainless Steel

**Caseback:** Stainless Steel

**Strap:** Polyurethane

#### Mode Limits:

**Chronograph:** 23:59'59"

**Heart Rate:** 30 - 240 bpm

**Timer:** 23:59'59"

### Heart Rate Transmitter

#### Water Resistant up to 30 Meters:

Wipe dry after use. Do not store among conductive material.

**Operating Temperature:** -5 to 50° Celsius

**Accuracy:**  $\pm 1\%$  or  $\pm 1\%$  bpm, whichever larger (steady state)

#### Material Specifications:

**Case:** Polycarbonate

**Strap:** Urethane

**Band:** Elastic



# Battery

**WARNING!** Keep watch batteries away from children. If swallowed, contact a doctor immediately.

**WARNING!** Batteries contain chemical substances. They should be disposed of properly according to local regulations.

## Watch

**Battery Type:** CR2032 3V Lithium

### Battery Life:

The battery is estimated to last 1.5 years depending on frequency and use of certain features. Activating the Electrolyte feature will contribute to battery drain. Utilizing the Power Save function will help conserve battery life.

### Battery Replacement:

Follow steps below to replace your watch battery. *For best results, you can have Nike's authorized service center change the watch battery.*

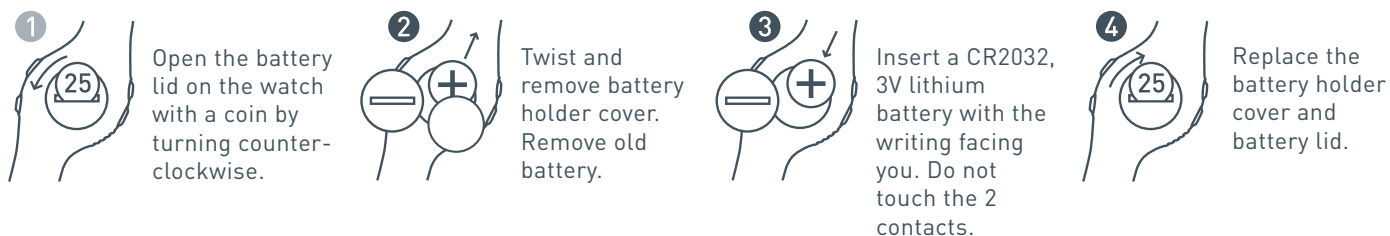

## Heart Rate Transmitter

**Battery Type:** CR2032 3V Lithium

### Battery Life:

The battery is estimated to last 1 year if HR Transmitter is used one hour per day.

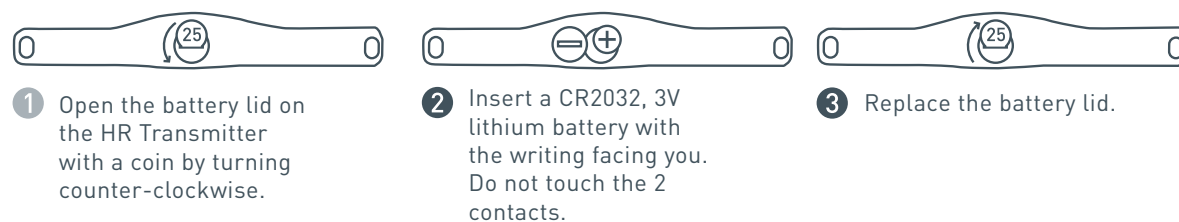

## Two-Year Limited Warranty

Your NIKE watch is warranted to be free of defects in materials or workmanship, under normal use, for a period of two years from the date of delivery. This limited warranty excludes the battery, crystal, strap, or damage resulting from improper care or handling, accidents, modification, unauthorized repairs or normal wear.

Return the defective watch and the store receipt to the place of purchase. If there is a covered defect, you have the option to have the defective parts or watch repaired or replaced with the same product (if available) or a similar product of equal price. However, NIKE reserves the right to refuse either repair or replacement (but not both) if the cost of doing so would be disproportionate to the defect.

This limited warranty is in place of all other express warranties, and excludes refund of the purchase price. Any implied warranties, including merchantability and fitness for a particular purpose, are limited to the duration of this limited warranty. In no event shall NIKE be liable for direct, indirect, incidental or consequential damages arising out of the use of the watch, and any recovery is limited to the purchase price. No other person or company is authorized to change this limited warranty, and your dealer is solely responsible for any other warranties.

For U.S. Purchasers: Some states do not allow limitations on how long an implied warranty lasts, or exclusions of incidental or consequential damages, so the above limitations may not apply to you. This warranty gives you specific legal rights, and you may also have other rights which vary from state to state.

The foregoing is without prejudice to other legal rights that may arise under applicable national legislation.

For non-warranty service like battery or strap replacement, contact one of the listed service centers.

## CE Compliance

This product complies with the Medical Device Directive (Directive 93/42/EEC).



## Service Centers

**USA:** 800-359-2508  
Parsec Enterprises, Inc.  
7501 N. Harker Dr.  
Peoria, IL 61650  
**Denmark:** +45 45932233  
**France:** +33 1 42 72 03 33  
**UK:** +44 1628 770988  
**Germany:** +49 2154 943 471  
**Netherlands:** +31 104009899  
**Belgium:** +00 32 2 468 32 05  
**Italy:** +39 2 72000980  
**Norway:** +47 67 51 20 87  
**Sweden:** +47 67 51 20 87  
**Austria:** +43 13313937  
**Finland:** +358 9 4780 500  
**Switzerland:** +41 32 321 7272  
**Spain:** +34 93 419 5888  
**Greece:** +30 32 12293  
**Slovenia:** +386 4 202 70 16  
**Croatia:** +385 1 4816 137  
**Hungary:** +36 1 267 4797  
**Israel:** +972-3-5172540  
**Turkey:** +90 (212) 513 62 90  
**CIS:** 7 095 232 0115  
**UAE:** +971 43 59 99 05  
**Saudie Arabia:** +966 1 2930 920  
**Lebanon:** +961 1 746540  
**Egypt:** +20 (0) 22673811  
**Japan:** 0120-500-719  
**Korea:** 080-022-0182  
**Singapore:** 65-788 0990  
**Malaysia:** 603-7722 2459  
**Thailand:** 662-676 6100  
**Philippines:** 632-848 9851  
**Australia:** 1300 656 453  
**Taiwan:** 0800-009-868