

TIME

In TIME mode you can set time and calendar information and adjust your watch's display settings.

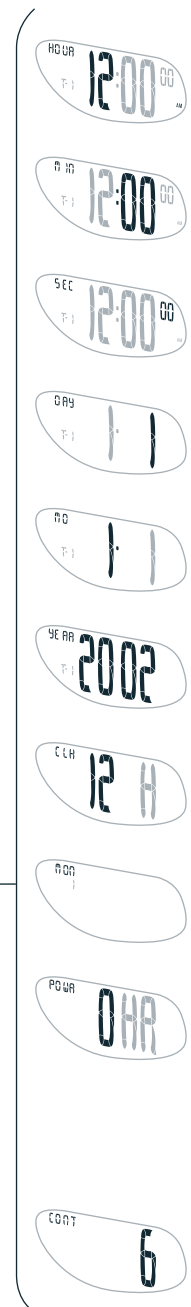
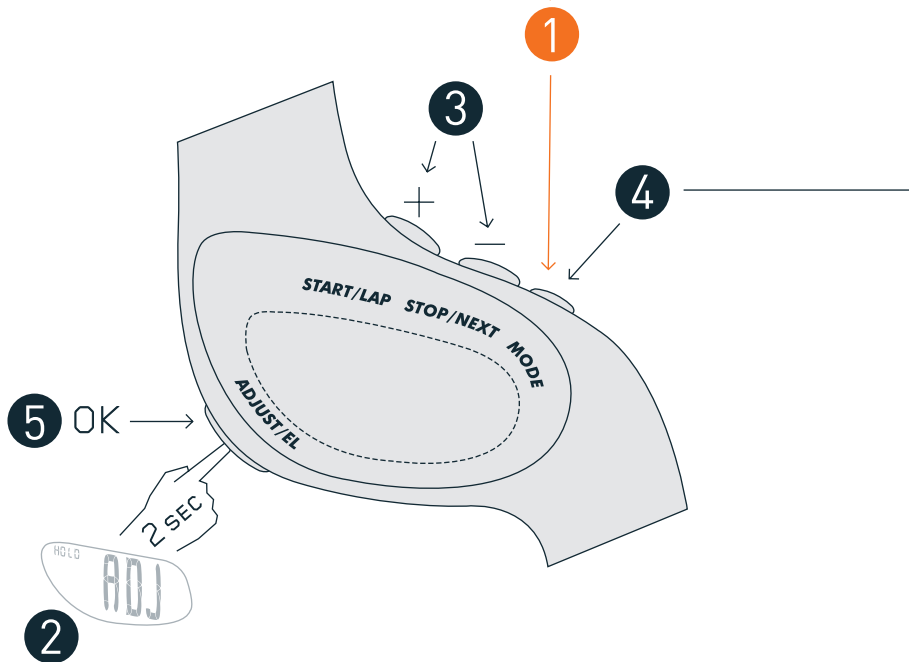

Powersave: Display shuts off at specified time to conserve battery. Press any button to turn watch on.

Adjust Screen Contrast

Time Warp
Hold for 1 second in any other mode to return to TIME.

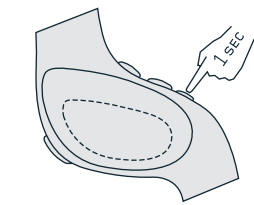

Chime On/Off

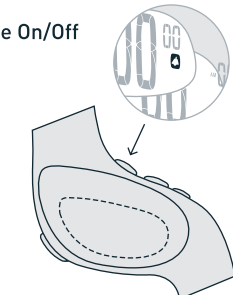

Switch Time Zones

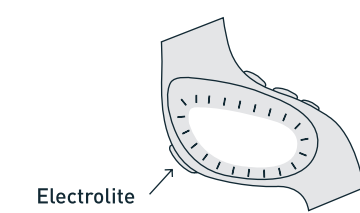
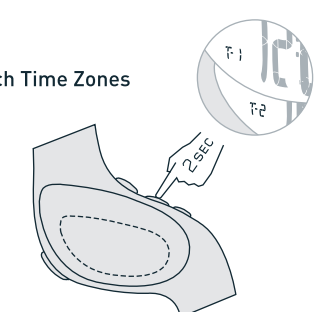



In CHRONOGRAPH mode you can set your distance to calculate pace; and capture lap, split and run times. Save your times for review in DATA mode.

Set Distance to calculate pace

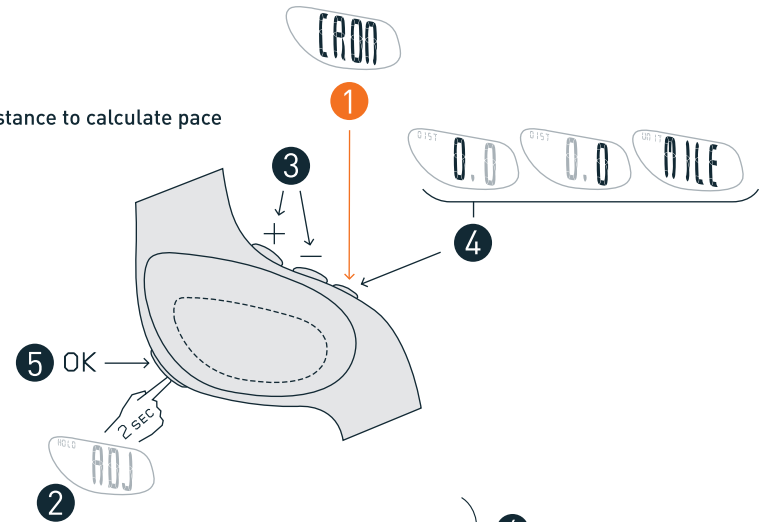

Choose Display: Lap/Split

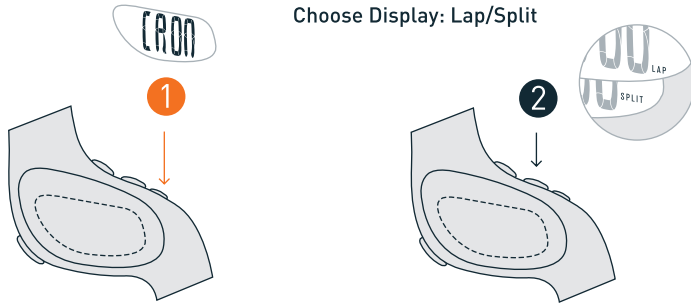

Mark Laps

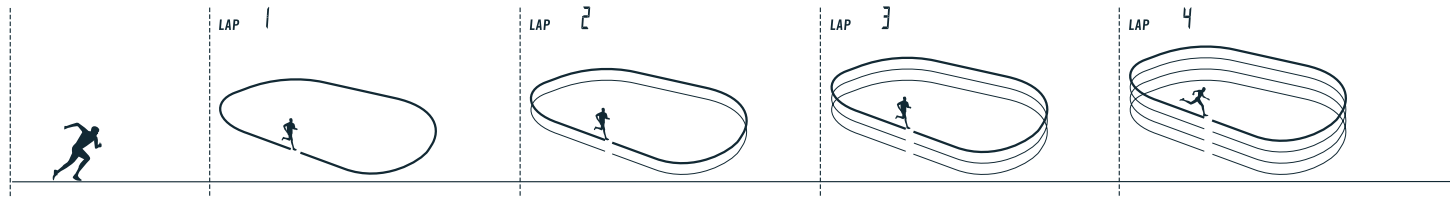

Or

Mark Splits



Start Run

Mark Lap/Split

Mark Lap/Split

Mark Lap/Split

Stop Run

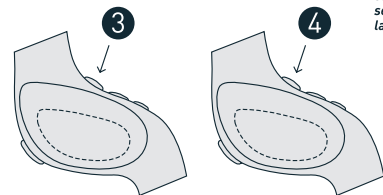

You will have 7 seconds to read your lap or split time.

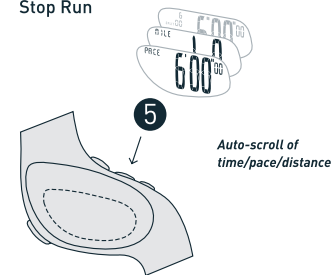
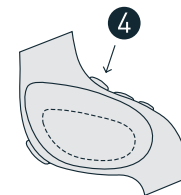
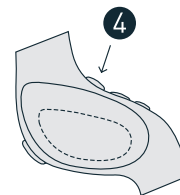

6 Choose Save Run Or Clear Run

Save

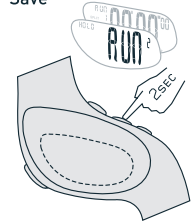

Clear

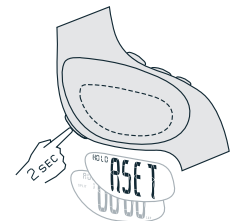

If watch is full, delete runs in DATA mode.

ALARM

In ALARM mode you can set 5 alarms that will sound for 55 seconds. Press any button to stop alarm.

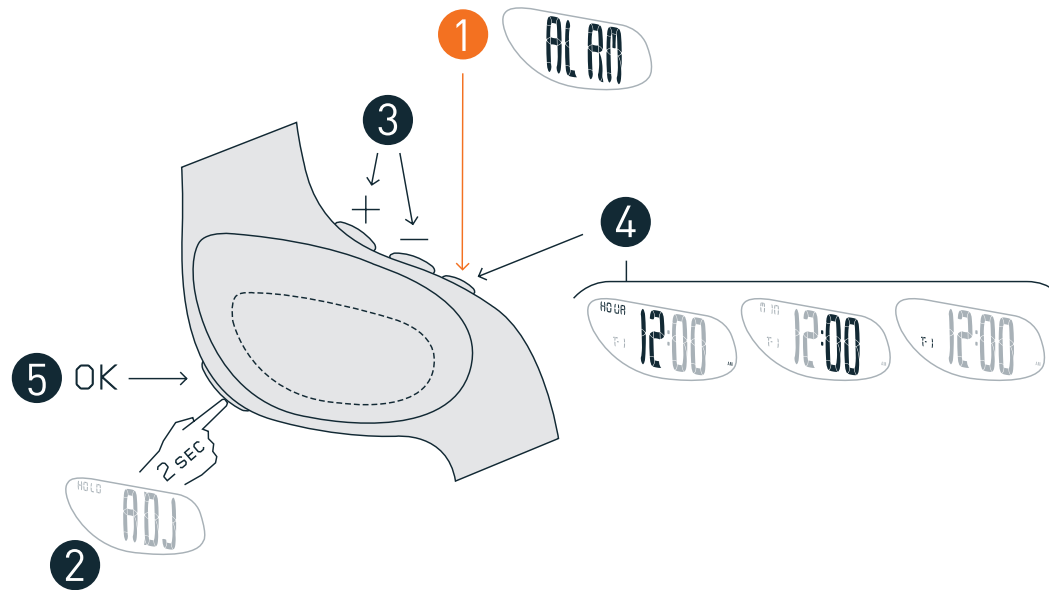

Alarm On/Off

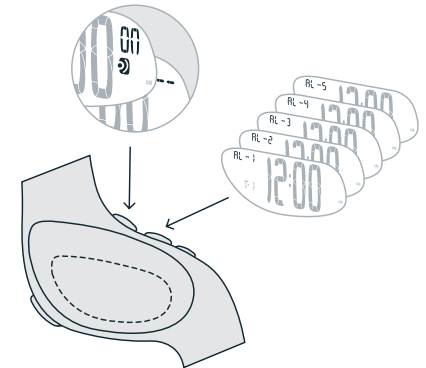

Turn All Alarms Off

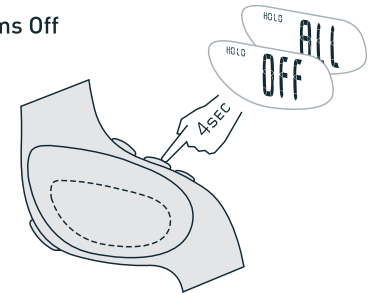

CNTA

In COUNTER mode you can count in positive and negative increments. Use COUNTER to keep track of golf strokes, baseball innings, running miles or other.

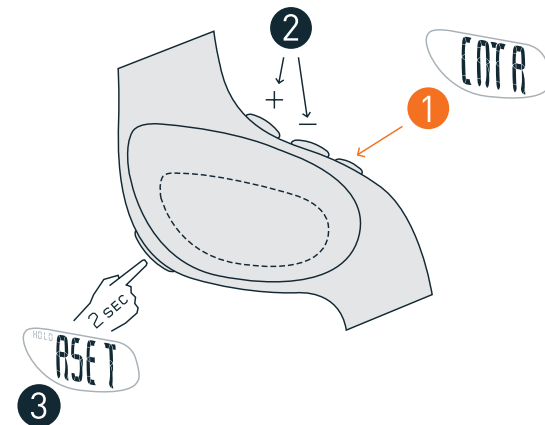

DATA

In DATA mode, you can review lap, split and run times.
Record and reset your times in CHRONOGRAPH mode.



View Lap/Split/Run Times

3



Choose a Run

2

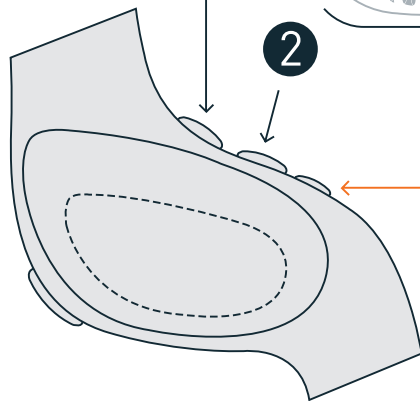

1

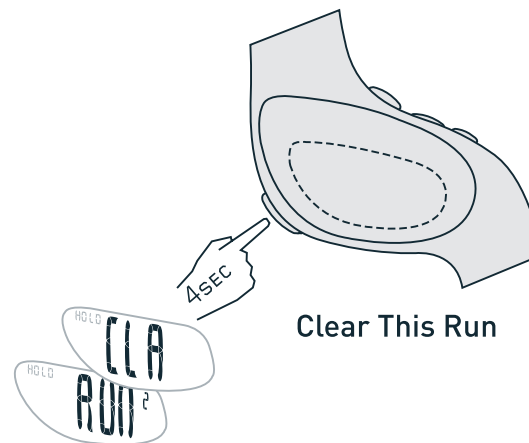

Clear This Run

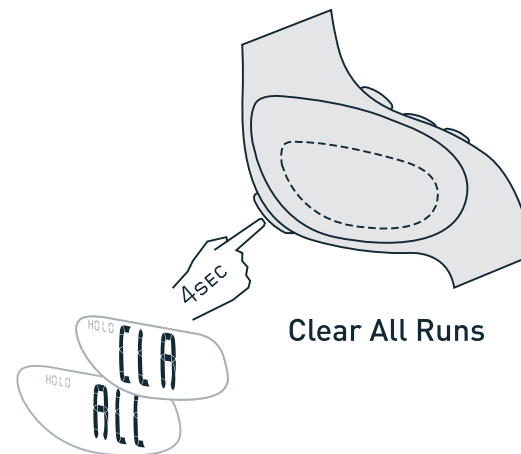

Clear All Runs

TIMER

In TIMER mode you can set up to 5 timed training segments.

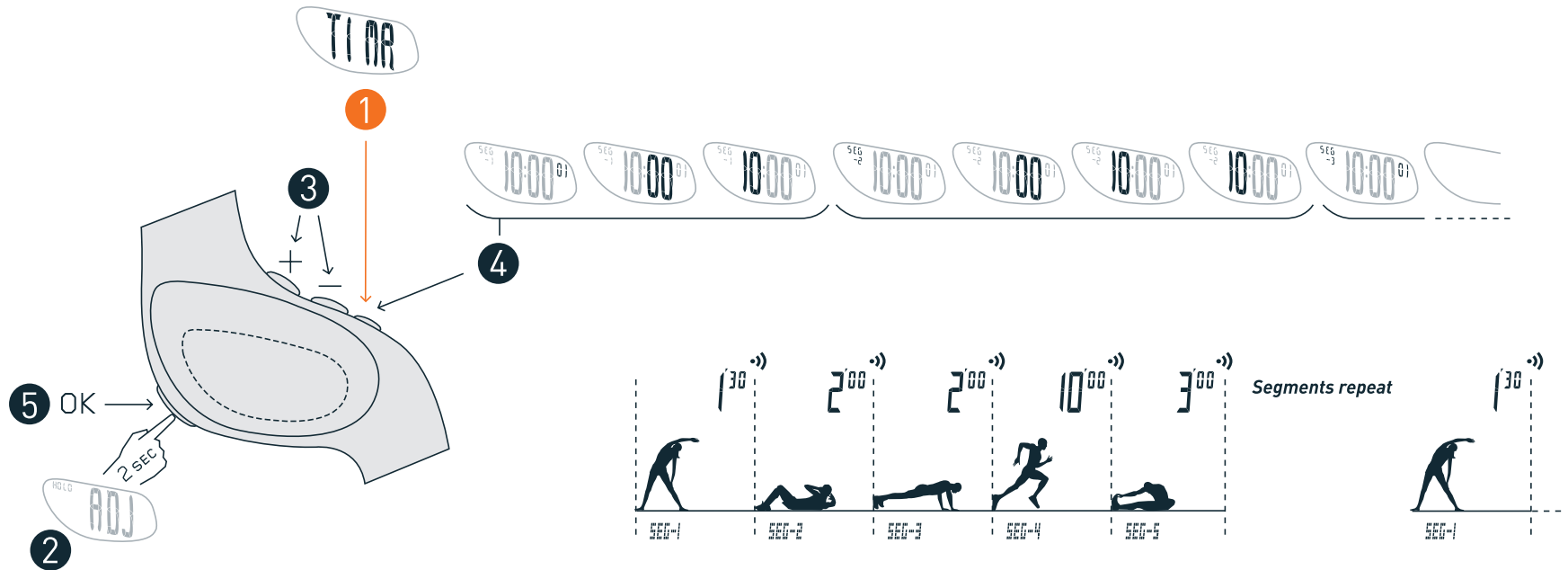

Start & Stop Countdown

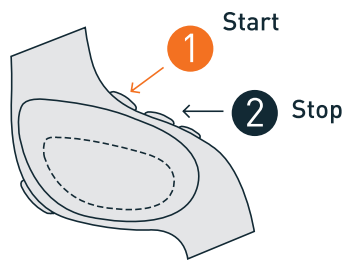

Reset Countdown



Cycle Segments

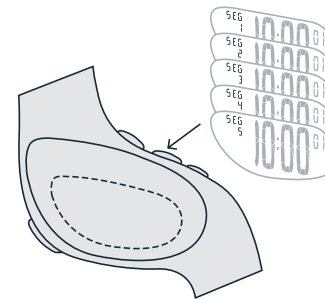

Clear All Segments

